

1996 Mitsubishi Montero LS

SYSTEM WIRING DIAGRAMS

Fig. 16: 3.0L 24 Valve, Engine Performance Circuits, Federal (1 of 3)

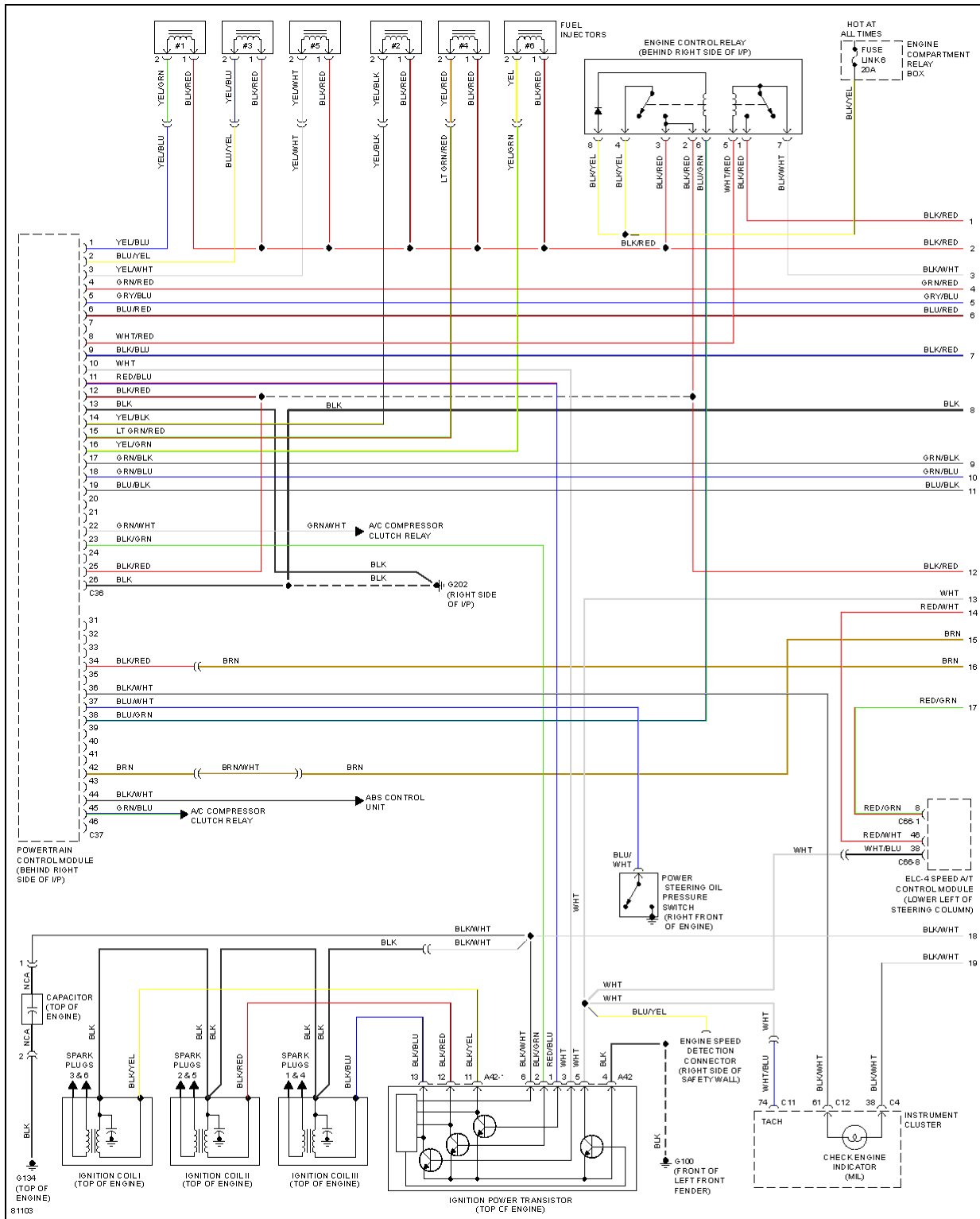

1996 Mitsubishi Montero LS

SYSTEM WIRING DIAGRAMS

Fig. 17: 3.0L 24 Valve, Engine Performance Circuits, Federal (2 of 3)

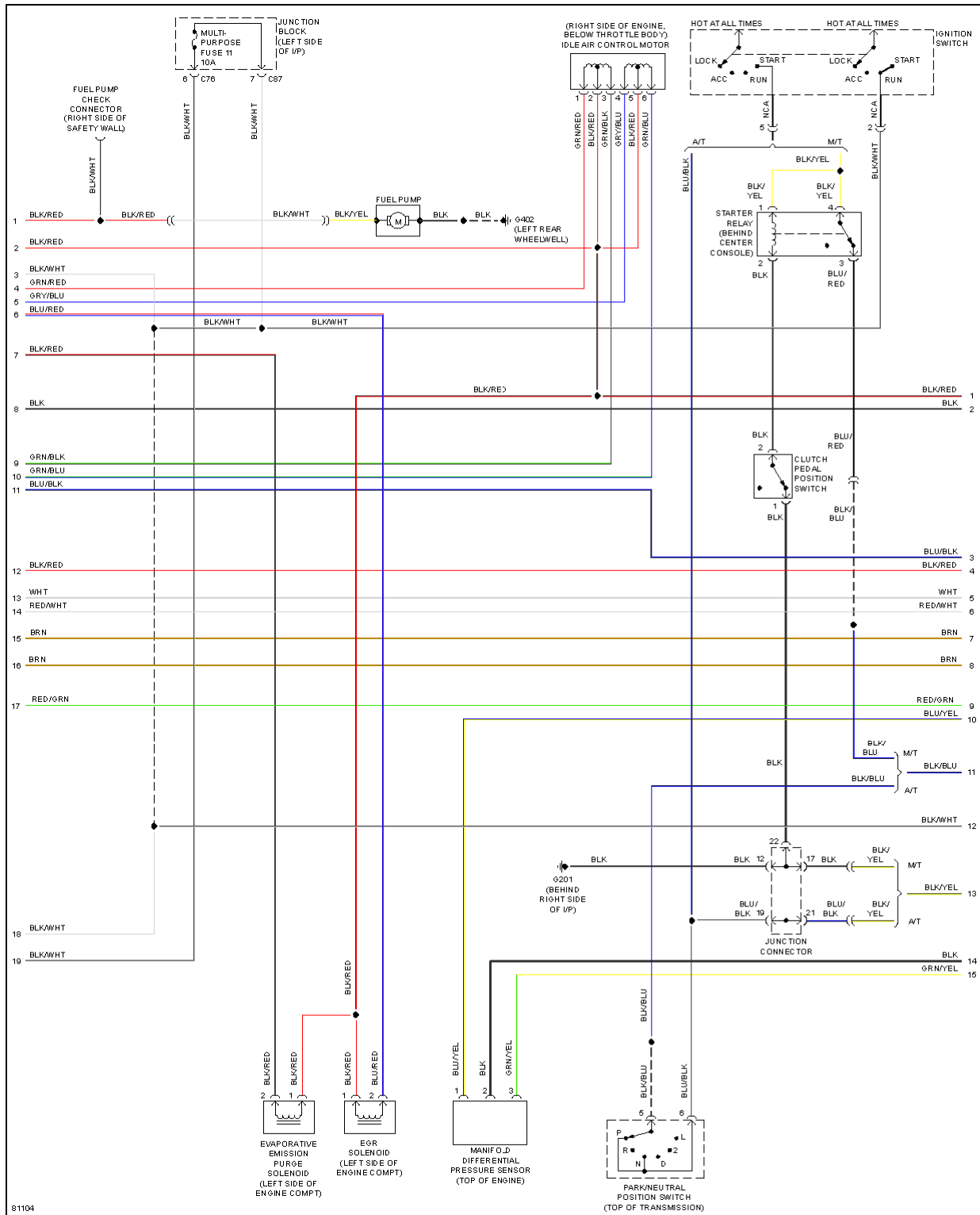

1996 Mitsubishi Montero LS

SYSTEM WIRING DIAGRAMS

Fig. 18: 3.0L 24 Valve, Engine Performance Circuits, Federal (3 of 3)

